

SAFETY INFORMATION

WARNING: Do not connect directly to high voltage power (120V-277V). Use only with 24V DC hardwire or plug-in power supply. Factory warranty will be void if used otherwise.

- Read complete instruction.
- These products may represent a potential shock or fire hazard if improperly installed or attached in any way. Products should be installed in accordance with these instructions, local electrical codes and the National Electric Code (NEC).
- Do not energize LED tapelight when rolled up in its spool.
- Uncoated products are intended for indoor use in dry locations. Coated products are intended for outdoor use or in damp/wet locations. Refer to product spec sheet for location ratings.
- Do not use if there is any damage to the unit or to the wiring/insulation. Inspect periodically.
- Do not route cords or LED tapelight through walls, doors, windows or any similar part of a building structure.
- Do not secure LED tapelight or its power cord with staples, nails, or any other sharp objects that may cause damage.
- Do not install LED tapelight closer than 6" to combustible material.
- Ensure proper gauge wires are installed between Power Supplies, Controls & LED tapelight to avoid voltage drop.
- Ensure applicable wires are in compliance with local codes (In-wall rated, wet-location, high temperature, etc.).
- Recommended load for power supplies is 80%.

✓ required components to complete installation

- LED Tapelight
- Connectors (if applicable)
- Extrusion / Lens
- Construction Adhesive
- 24V DC Power Supply

Tapelight DO-NOT basics

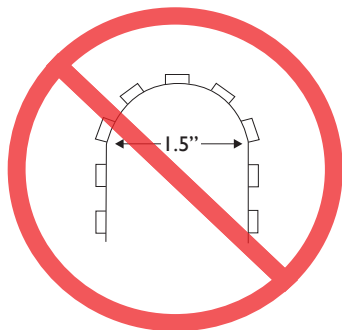

1.5" MINIMUM BEND RADIUS

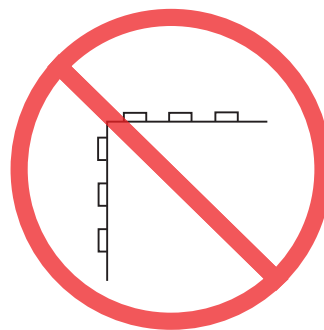

DO NOT FOLD OR CREASE
LED TAPELIGHT

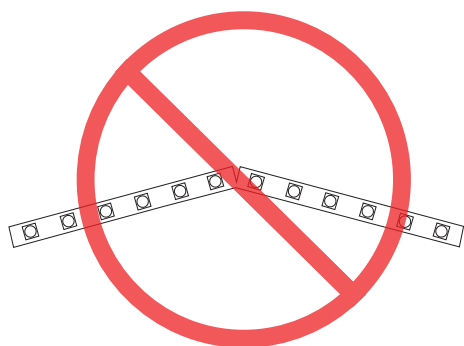

DO NOT BEND LED
TAPELIGHT SIDE TO SIDE

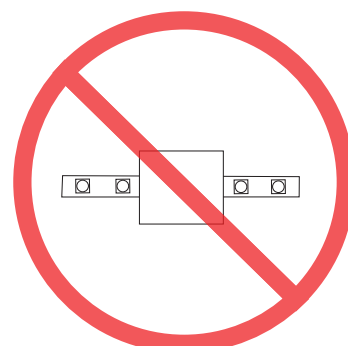

DO NOT COVER LED
TAPELIGHT OR APPLY EXCESS
PRESSURE TO LED TAPE

Assemble Parts Together

1

INSTALLATION NOTES:

- Review all parts and quantities to confirm if all necessary parts are available.
- LED tapelight can only be cut at specific points. It is essential to dryfit your entire assembly to the cut point of your LED tapelight before routing/cutting out the mounting surface.

CAUTION: Use proper safety equipment when making any modification to parts.

- 1.1 If necessary, extrusion and lens can be cut on-site, using the proper equipment that cuts aluminum. Carefully cut to the desired length followed by cleaning off any material left after the cut.
- 1.2 Remove the lens from inside the extrusion, followed by cleaning the inside of the extrusion from any debris.

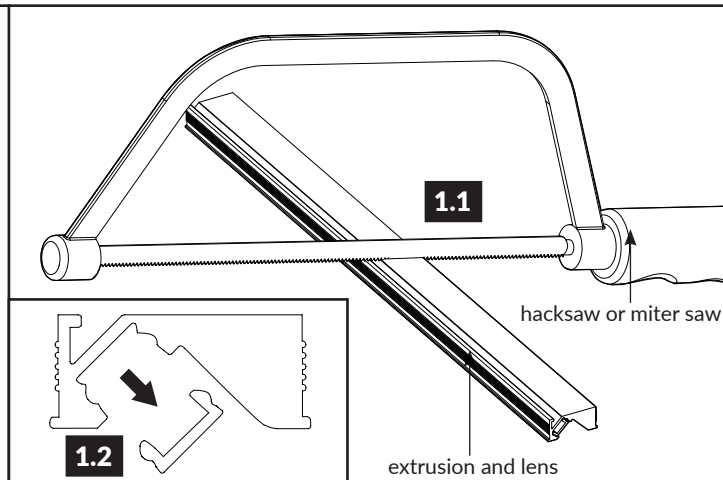

2

INSTALLATION NOTES:

- If using endcap with hole for the powerfeed, disregard this step.
- Prior to making any holes to the extrusion, determine what side of the extrusion would need the wire leads.

- 2.1 From the top of the extrusion, carefully make a 3/16" hole about 1/4" from the end.

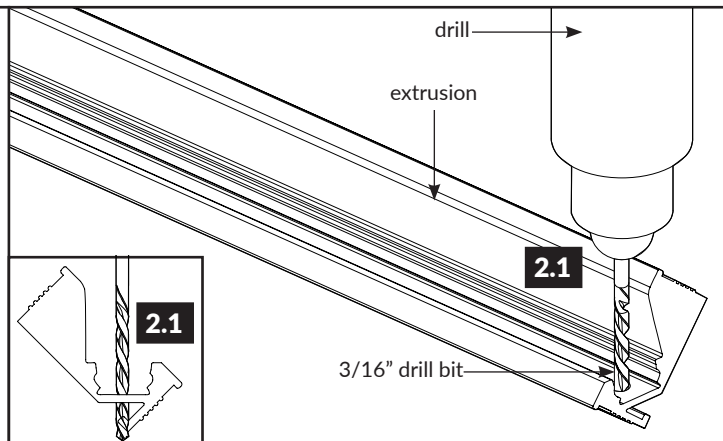

3

- 3.1 If shortening the LED tapelight, cut along the cut marks that are labeled in between the solder pads using utility shears.
- 3.2 Remove the red adhesive backing from the LED tapelight, then carefully apply the LED tapelight to the inside of the extrusion.

INSTALLATION NOTES:

- Make sure not to cut the side of the tapelight with lead wires.

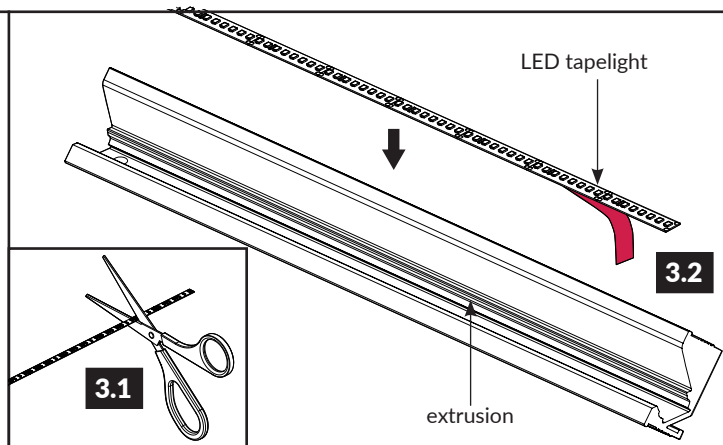

Assemble Parts Together

4

- 4.1 Carefully snap the lens into the top of the extrusion.
- 4.2 Push endcaps completely into the extrusion to secure.

INSTALLATION NOTES:

- If using endcaps with hole, slide the endcap carefully through the power feed wire. Do not pull excessively on the power feed wires which can rip from the LED tapelight.

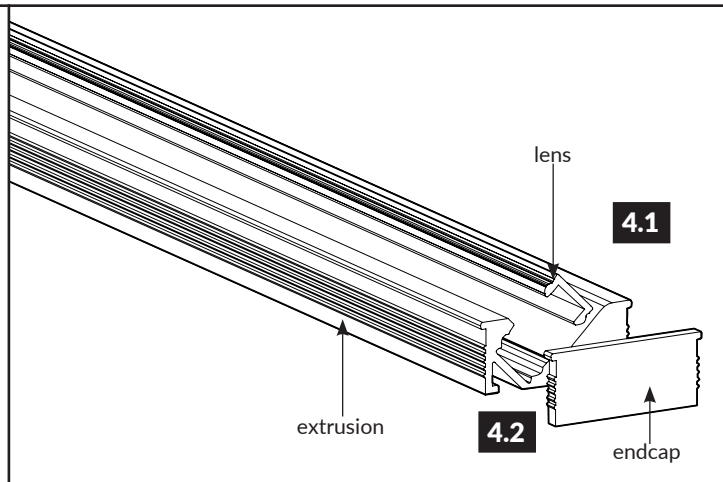

5

INSTALLATION NOTES:

- If needed pre-install blocking & or use construction adhesive to secure properly into place.
- Make sure the remote power supply wires are near enough to connect later with the LED tapelight.

- 5.1 Press fit extrusion into the cavity.
- 5.2 Make the wiring connections in accordance with local & national electrical codes. For additional information reference the power supply instruction. General wiring diagram on page 5.

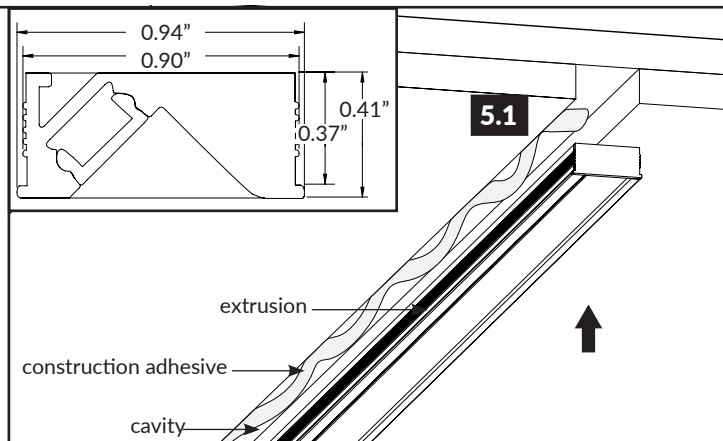

Cutaway View

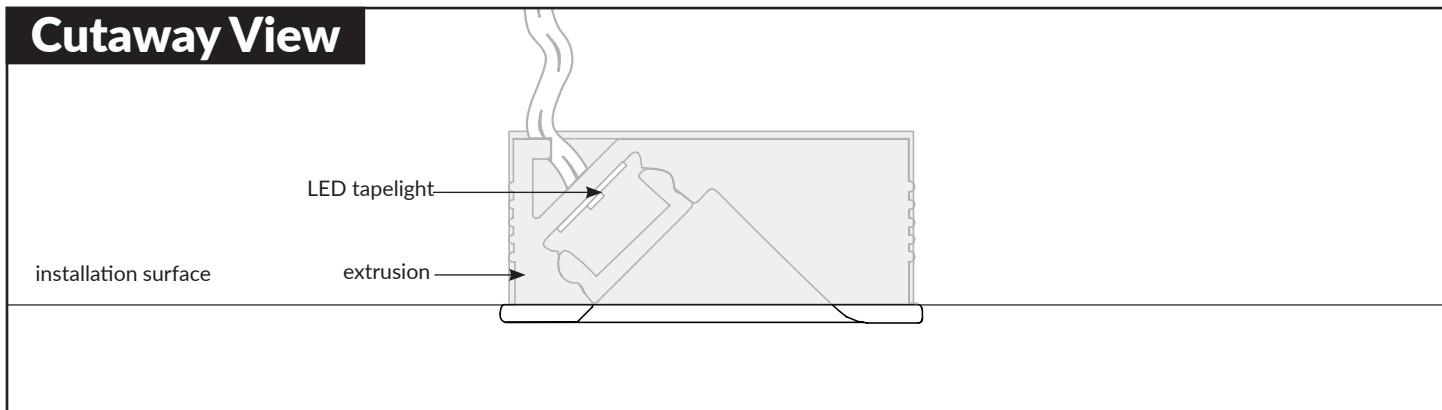

Low Voltage Wire Gauge Chart

24V DC Voltage Drop and Wire Length (ft.) Distance Chart													
Power (W)	10W	20W	30W	40W	50W	60W	70W	80W	90W	100W	110W	120W	
Wire Gauge	#18	189'	94'	63'	47'	38'	31'	27'	24'	21'	19'	17'	16'
	#16	300'	149'	100'	76'	60'	50'	43'	37'	33'	30'	27'	25'
	#14	478'	238'	159'	120'	95'	79'	68'	60'	53'	48'	43'	40'
	#12	753'	274'	250'	189'	150'	125'	108'	94'	83'	75'	68'	63'
	#10	1205'	599'	400'	303'	240'	200'	172'	150'	133'	120'	109'	100'

Typical Wiring Diagram - Static Color

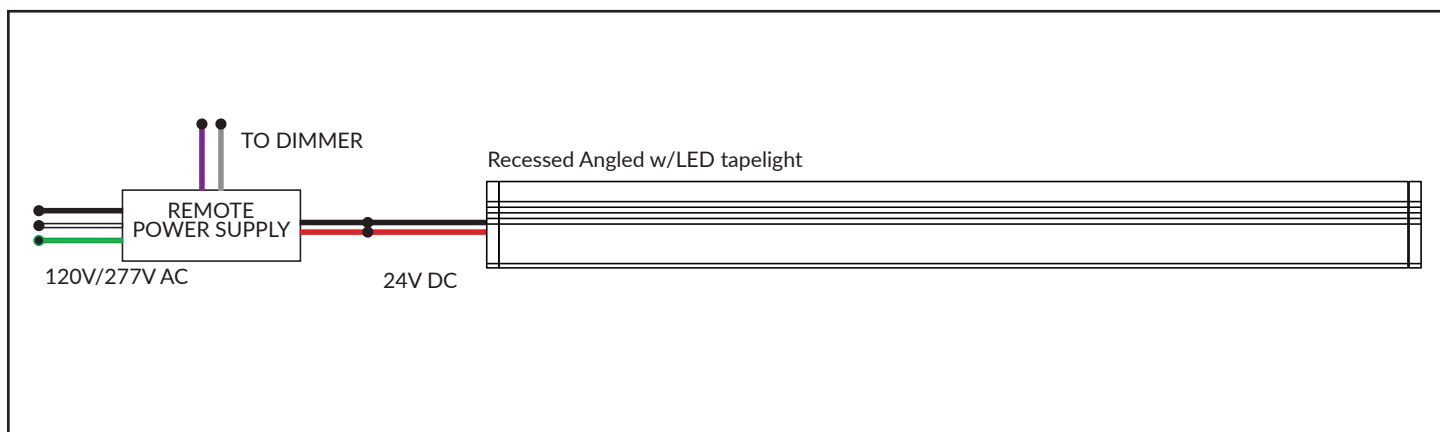

Typical Wiring Diagram - Dynamic Color

